

Tilia

Installation manual

220-240V, 50/60Hz

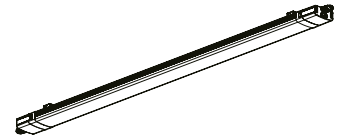

Please read the instruction manual before installation and keep it for future reference.

Intended use:

EN: The luminaire is meant for standard use in damp environments and in outdoors areas which are covered by roofs. The luminaire is unsuitable for corrosive atmospheres (e.g. swimming pools, intensive animal husbandry, tunnels).

DE: Die Leuchte ist bestimmungsmäßig für die Montage in feuchter Umgebung und in überdachten Außenbereichen geeignet. Die Leuchte ist nicht für den Einsatz in korrosiven Umgebungen (z.B. Schwimmbäder, Tierhaltung, Tunnel) geeignet.

SE: Armaturen är avsedd för standardanvändning i fuktiga miljöer och i utomhusområden som är täckta av tak. Armaturen är inte lämplig för korrosiva miljöer (t.ex. simbas-sänger, intensiv djuruppfödning, tunnlar).

Safety instructions:

EN: These instructions assume expert knowledge corresponding to a completed professional education as an electrician.

DE: Diese Anleitung setzt Fachkenntnisse voraus, die einer abgeschlossenen Berufsausbildung als Elektrofachkraft entsprechen.

SE: Dessa instruktioner förutsätter expertkunskaper motsvarande en avslutad yrkesutbildning som elektriker.

EN: Never work when voltage is present on the luminaire. Caution - Risk of fatal injury!

DE: Es dürfen keine Arbeiten unter Spannung vorgenommen werden! Vorsicht Lebensgefahr

SE: Arbete aldrig när det finns spänning på armaturen. Varning - Risk för livsfarliga skador!

EN: Ensure that the luminaire is undamaged before installation and commissioning!

DE: Stellen Sie sicher, dass die Leuchte vor der Installation und Inbetriebnahme unbeschädigt ist!

SE: Se till att armaturen är oskadad före installation och idrifttagning!

EN: The manufacturer is not liable for any damage caused by incorrect or unauthorized use or by non-observance of these instructions.

DE: Der Hersteller haftet nicht für Schäden, die durch unsachgemäßen oder unbefugten Gebrauch oder durch Nichtbeachtung dieser Anleitung entstehen.

SE: Tillverkaren ansvarar inte för skador som orsakas av felaktig eller obehörig användning eller av att dessa anvisningar inte följs.

EN: Work on the luminaire (installation, maintenance, servicing, troubleshooting) may only be carried out by authorized electrician.

DE: Arbeiten an der Leuchte (Installation, Wartung, Instandhaltung, Fehlersuche) dürfen nur von einer autorisierten Elektrofachkraft durchgeführt werden.

SE: Arbete på armaturen (installation, underhåll, service, felsökning) får endast utföras av behörig elektriker.

5-Year warranty policy

Aura Light offers a 5-year warranty regarding manufacturing and material defects in products manufactured and/or sold by Aura Light, provided that the product information for the product in question in digital form via www.auralight.com



Non-replaceable light source

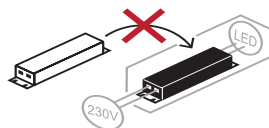

Non-replaceable control gear



Technical information can be found at www.auralight.com

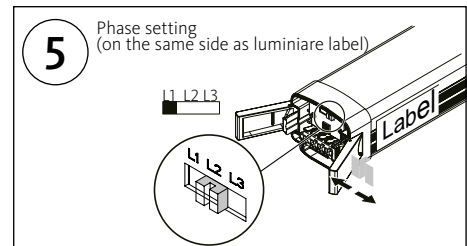
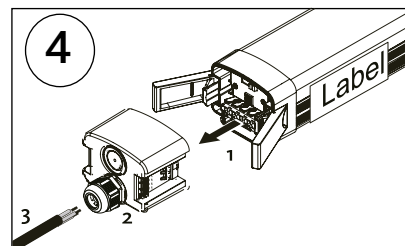
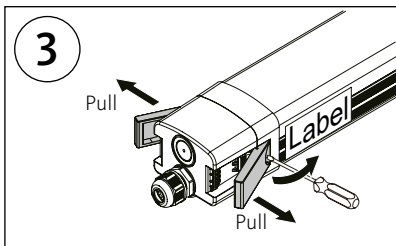
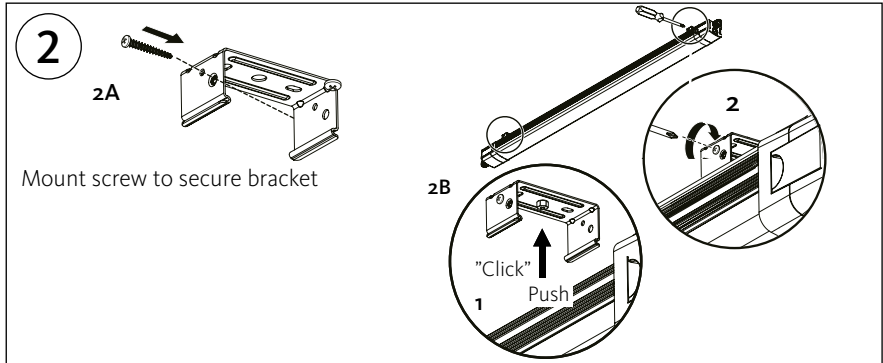
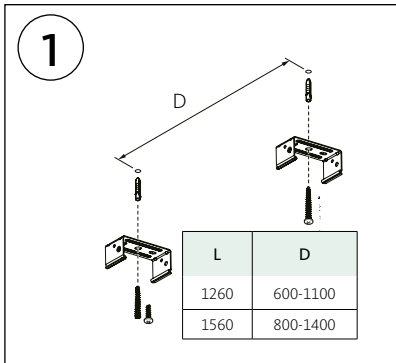

6

ON DP
12 3

Wattage setting (on same side as label)

1.2M...				1.5M...			
1	2	3	Power (w)	1	2	3	Power (w)
-	-	-	50	-	-	-	60
On	-	-	42	On	-	-	50
-	On	-	36	-	On	-	42
-	-	On	28	-	-	On	32

